

VERTICAL CENTER OF GRAVITY / WEIGHT DISTRIBUTION

4/3/2009

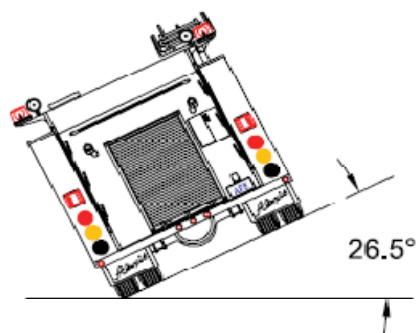
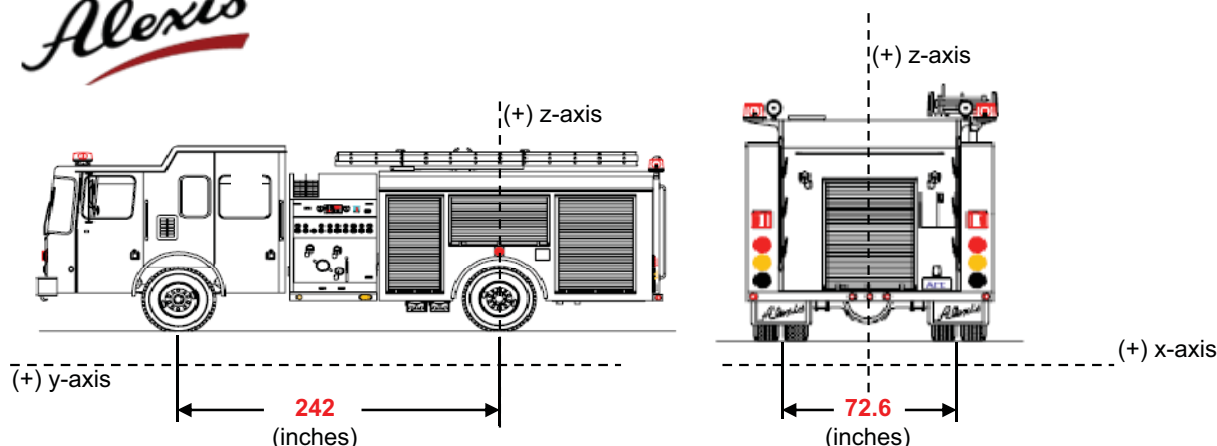

Contract or  
 Proposal Name: **Alexis Fire Equipment**  
 Calculated By: **Gerald Wilson**  
 Approved By:  
 Revision:  
 Type of Chassis: **International 7500 2dr**  
 Type of Pump: **Waterous CXVK 1250**  
 Cab to Axle: **174.9**  
 Tank Capacity: **3000**

| Item                       | Weight (lbs) | Coordinates Local C.G. (in)     |      |      | % Rear | Weight (lbs) |       |
|----------------------------|--------------|---------------------------------|------|------|--------|--------------|-------|
|                            |              | x                               | y    | z    |        | Front        | Rear  |
| Chassis                    | 16900        | 0                               | 131  | 55   | 46%    | 9160         | 7740  |
| Poly Tank (w/water)        | 27750        | 0                               | 28   | 76   | 88%    | 3211         | 24539 |
| Officer & Driver           | 500          | 0                               | 192  | 70   | 21%    | 397          | 103   |
| Men & Equip. (cab)         | 0            | 0                               | 0    | 0    | 0%     | 0            | 0     |
| Pump Module                | 500          | 0                               | 154  | 59   | 36%    | 318          | 182   |
| Pump                       | 600          | 0                               | 163  | 34   | 33%    | 404          | 196   |
| Body Module                | 2500         | 0                               | 25   | 38   | 90%    | 258          | 2242  |
| Hose Bed                   | 1000         | 0                               | 18   | 107  | 93%    | 74           | 926   |
| Add. Equip. front          | 1000         | 0                               | 95   | 38   | 61%    | 393          | 607   |
|                            | 0            | 0                               | 0    | 0    | 0%     | 0            | 0     |
| Preconnects                | 400          | 0                               | 162  | 92   | 33%    | 268          | 132   |
| Zico Electric Folding Tank | 800          | -45                             | 25   | 75   | 90%    | 83           | 717   |
| Side Dumps                 | 500          | 0                               | -64  | 44   | 126%   | -132         | 632   |
| Rear Dump                  | 250          | 0                               | -90  | 50   | 137%   | -93          | 343   |
|                            | 0            | 0                               | 0    | 0    | 0%     | 0            | 0     |
| Suction Hose               | 250          | 0                               | 25   | 94   | 90%    | 26           | 224   |
| Ladders                    | 500          | 43                              | 20   | 74   | 92%    | 41           | 459   |
|                            | 0            | 0                               | 0    | 0    | 0%     | 0            | 0     |
|                            | 0            | 0                               | 0    | 0    | 0%     | 0            | 0     |
|                            | 0            | 0                               | 0    | 0    | 0%     | 0            | 0     |
|                            | 0            | 0                               | 0    | 0    | 0%     | 0            | 0     |
| Total                      | 53450        | <b>Global Center of Gravity</b> |      |      |        | 14407        | 39043 |
| GAWR                       | 62000        | x                               | y    | z    |        | 16000        | 46000 |
| Load as % of Total         | 100%         | -0.3                            | 65.2 | 66.5 |        | 27%          | 73%   |

Truck Tipping Angle: **28** degrees (Full Water Tank) **OK**